

## SSC Series Electronic Valve Actuator

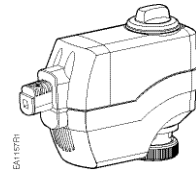

### Product Description

The SSC series actuator requires a 24 Vac, Class 2 supply and provides a 0 to 10 Vdc or Floating (three-position) control signal. The actuator controls a Powermite™ 599 Series MT Series valve with a 7/32-inch (5.5-mm) stroke.

### Warning /Caution Notations

|                 |  |   |
|-----------------|--|---|
| <b>WARNING:</b> |  | Personal injury or loss of life may occur if you do not perform a procedure as specified. |
| <b>CAUTION:</b> |  | Equipment damage or loss of data may occur if you do not follow a procedure as specified. |

### Product Numbers

|          |  |
|----------|--|
| SSC61U   | 0 to 10 Vdc, proportional control, non-spring return (fail-in-place) |
| SSC61.5U | 0 to 10 Vdc, proportional control, spring return (fail-safe)         |
| SSC81U   | Floating control, non-spring return (fail-in-place)                  |
| SSC81.5U | Floating control, spring return (fail-safe)                          |

### Contents

One SSC actuator

### Estimated Installation Time

20 minutes

### Required Tools

- Small Phillips head screwdriver
- Small flat-blade screwdriver
- Wire stripper

### Prerequisites



#### WARNING:

1. If mounting the actuator to a valve already in line, either close the shut-off in the piping (upstream first, then downstream) or switch off the pump to allow the differential pressure in the valve to drop.
2. Disconnect the controller power before replacing the actuator.
3. If high voltage cable is co-located with the SSC actuator, conduit or shielded wire may need to be used.



#### CAUTION:

Before applying power, make certain a valve is connected to the actuator.

If applying power to the actuator when a valve is not connected, the actuator will respond to a control signal and the shaft will extend until it reaches its maximum end stop. Thereafter, it will not respond to any signal.

If this occurs, disconnect the power. Turn the manual position indicator on the top of the actuator to the **0** position and verify the actuator shaft retracts completely. See Figure 4.

Connect a valve to the actuator and reapply the power. The actuator will return to normal operation.

### Mounting

The vertical position is recommended for mounting the actuator. See Figure 1.

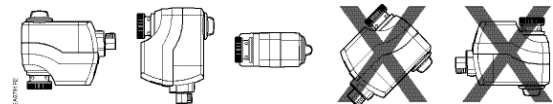

Figure 1.

#### Acceptable Actuator Mounting Positions.



#### CAUTION:

Mount actuator at a 45° angle from vertical when using on low pressure steam systems to reduce radiant heat that can damage the actuator.

## Installation

If you are mounting an actuator on a new valve, begin with the instructions *Mounting an Actuator on a Valve*.

### Removing the actuator from a valve

1. Remove the terminal cover (Figure 2) using a Phillips head screwdriver.
2. Identify and disconnect wiring from the terminals.
3. Remove wiring retention screw.
4. Do one of the following:
  - Remove plenum cable adapter and plenum cable;  
or
  - Remove flex conduit.
5. Loosen the actuator coupling on the valve (Figure 3, reverse No. 2).
6. Remove the actuator from the valve.

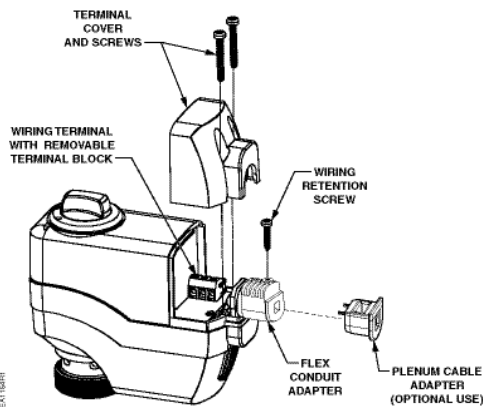

Figure 2. SSC Actuator Components.

### Mounting an Actuator on a Valve

1. If you are attaching the actuator to a new valve, remove the protective plastic cap from the valve stem.
2. Turn the manual position indicator on the top of the actuator to the **0** position (Figure 11).
3. Using a Phillips head screwdriver, remove the terminal cover (Figure 2).
4. Remove wiring retention screw.
5. Remove plenum cable adapter.
6. For plenum applications, complete wiring as follows:

- a. Route cable through plenum cable adapter so there is sufficient cable to complete wiring terminations.
- b. Insert plenum cable adapter into flex conduit adapter and secure in place with wiring retention screw.

**NOTE:** Insert wiring retention screw in hole of the flex conduit adapter. (The hole nearest the wiring terminals is to secure the terminal cover in place.)

- c. Continue with Step 8.

7. For 3/8-inch flex conduit applications, complete wiring as follows:
  - a. Discard plenum cable adapter.
  - b. Insert flex conduit into flex conduit adapter and secure in place with wiring retention screw.
 

**NOTE:** Insert wiring retention screw in hole of the flex conduit adapter. (The hole nearest the wiring terminals is to secure the terminal cover in place.)
  - c. Route wiring through flex conduit for wiring terminations.
8. Connect wires to wiring terminals per the *Wiring* section of this document.
9. Secure the terminal cover in place over the wiring terminals (Figure 2) using a Phillips head screwdriver,
10. Place the actuator on the valve and firmly hand-tighten (Figure 3).



### CAUTION:

Hand-tighten the actuator to the valve. Using tools to tighten the assembly together, will cause damage.

The installation is complete.

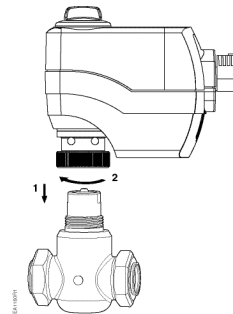

Figure 3. Coupling Actuator to Valve.

## Manual Override

To position the actuator manually, use the manual override knob in the center of the position indicator (Figure 4).

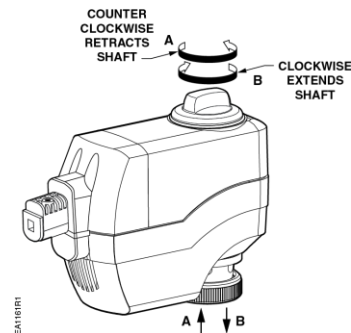
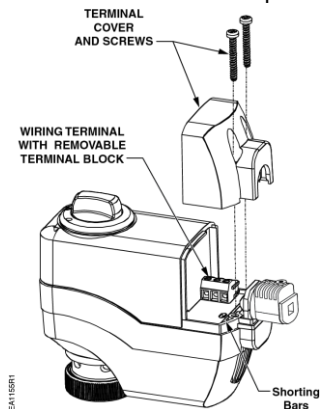

Figure 4. Manual Override.

## Calibration Stroke

The SSC Series writes its calibration stroke parameters to nonvolatile memory on the first start-up of the actuator. Successive start-ups bypass the calibration stroke unless the memory is manually cleared. If installing the actuator on a different valve (such as on a replacement valve), manually clear the calibration stroke from memory as follows:

1. Remove the terminal cover using a Phillips head screwdriver.
2. Locate hole on the circuit board with the shorting bars (Figure 5).
3. With power applied to the unit, insert and gently twist a flat-blade screwdriver to electrically connect the shorting bars. The SSC... then performs a new calibration stroke.
4. Secure the terminal cover back in place.



**Figure 5. Manually Clearing Calibration Stroke from SSC61U and SSC61.5U Nonvolatile Memory.**

## Wiring

- All wiring must conform to NEC and local codes and regulations.
- Use earth ground isolating, step-down Class 2 transformers. Do *not* use autotransformers.
- Determine the supply transformer rating by summing the total VA of all actuators used. The maximum rating for a Class 2 step-down transformer is 100 VA.
- Do not power more than 10 actuators with one transformer. (Use 0.5 amp on secondary actuators.)

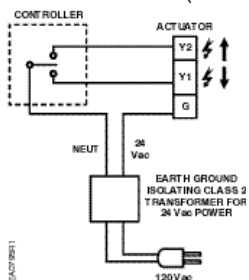

**Figure 6. SSC81U NSR Floating Control.**

Y2: Retracts actuator shaft  
 Y1: Extends actuator shaft  
 G: System potential

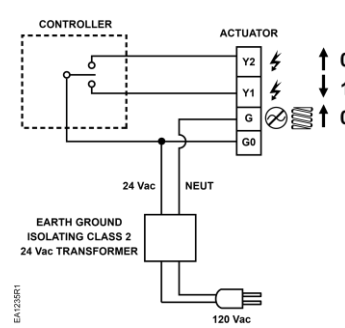

**Figure 7. For Non-Triac Driven Controllers.**

G, G0: 24 Vac operating voltage  
 Y2: Retracts actuator shaft

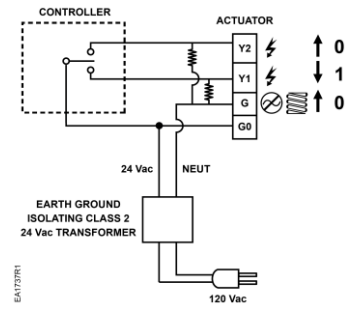

**Figure 8 For Triac Driven Controllers, (TEC, DXR, and Others).**

**SSC81.5U Floating Control SR Hot-Switch.**

Y1 Extends actuator shaft  
 G System neutral  
 G0 System potential (switched)



### CAUTION:

Terminals must be properly wired for correct function and full life of the actuator.

Because the triacs on TECs and DXRs always switch hot power, add a 1000 Ohm 2-Watt resistor across each of the binary (Y1, Y2) outputs (see **Error! Reference source not found.**). The two resistors must be used for all hot-switching triacs not just TEC and DXR.

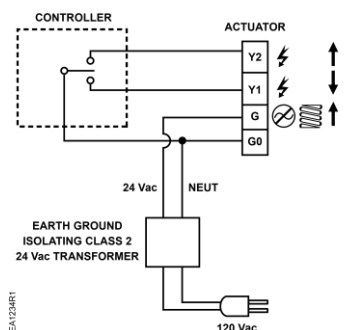

**Figure 9. SSC81.5U Floating Control SR Neutral Switching Applications.**

G, G0: 24 Vac operating voltage  
 Y2: Retracts actuator shaft  
 Y1: Extends actuator shaft  
 G: System potential  
 G0: System neutral (switched)

**NOTE:** For proper operation, it is recommended no more than three actuators be assigned to any single control signal.

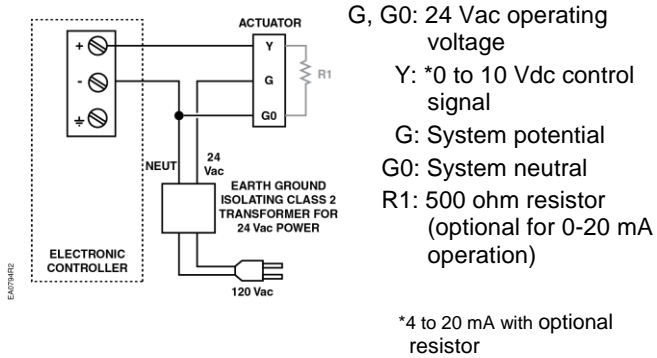

**Figure 10.**  
**SSC61U, NSR and SSC61.5U, SR,**  
**0 to 10 Vdc Proportional Control Wiring Diagram.**

### Start-up

Check the wiring and the position indicator (Figure 11).

| Position Indicator | Output Shaft |
|--------------------|--------------|
| 0                  | Retracted    |
| 1                  | Extended     |

**NOTE:**  
**0** and **1** markings are intended for reference only, and not stroke measurement.

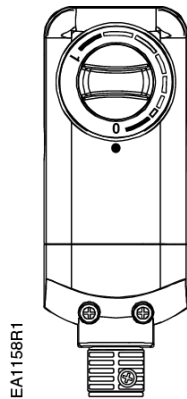

**Figure 11. Position Indicator (Shown in 0 Position).**

### Troubleshooting

Check the wiring for the proper connections.

### References

| Technical Instructions   | Document No. |
|--|--------------|
| EA 599-15 Powermite 599 Series SSC Electronic Valve Actuator 24 Vac Proportional Control   | 155-313P25   |
| EA 599-16 Powermite 599 Series SSC Electronic Valve Actuator 3-position (Floating) Control | 155-314P25   |
| TB251, Powermite 599 Series, MT Series Terminal Unit Valve and Actuator Assembly Selection | 155-306P25   |

## Dimensions

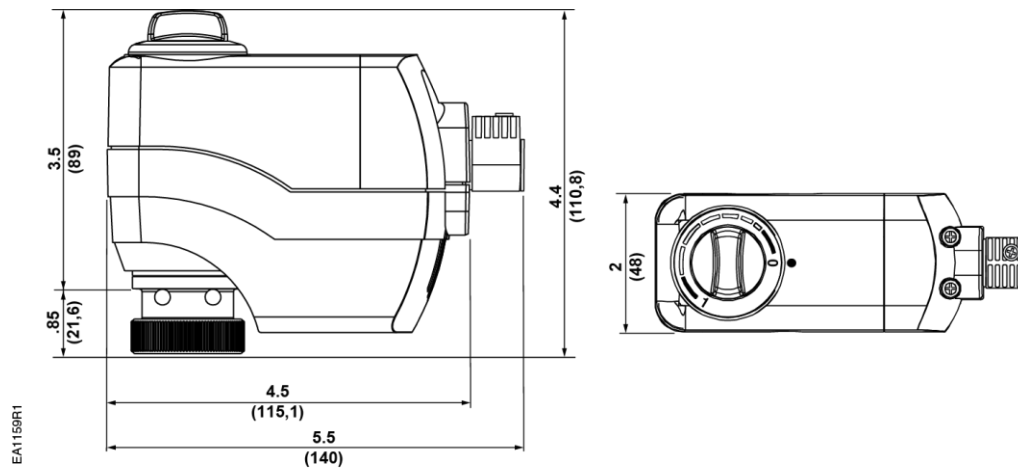

Figure 12. SSC Actuator Dimensions in Inches (Millimeters).

## Service Envelope

Minimum access space recommended:

1. 8 inches (200 mm) above the actuator.
2. 8 inches (200 mm) beside the terminal cover.

Information in this publication is based on current specifications. The company reserves the right to make changes in specifications and models as design improvements are introduced. Powermite is a trademark of Siemens Industry, Inc. Other product or company names mentioned herein may be the trademarks of their respective owners. © 2019 Siemens Industry, Inc.